

DASH NO.	DESCRIPTION	MADE FROM
----------	-------------	-----------

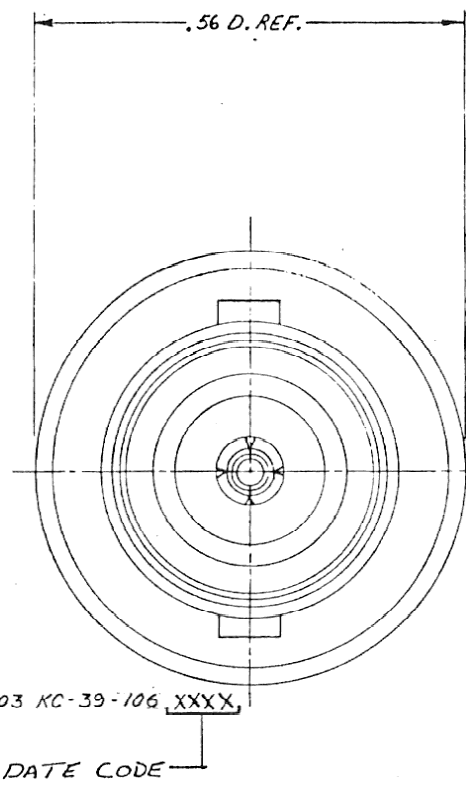
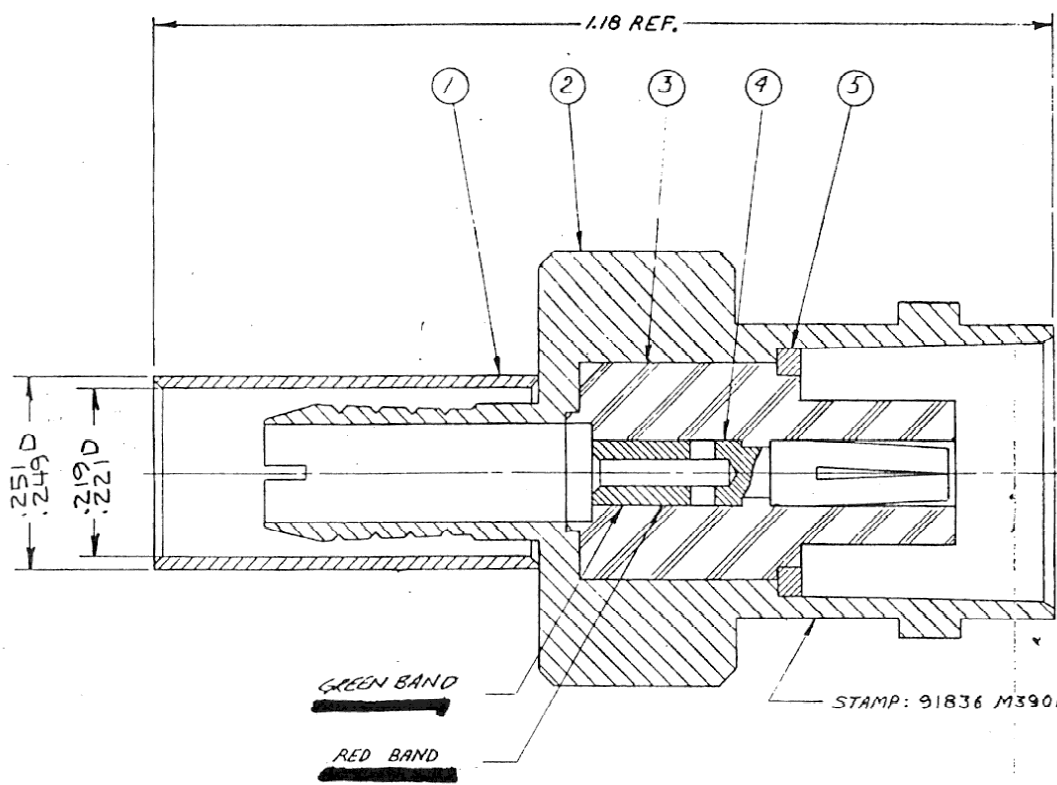

- NOTES:
- FOR USE WITH RG-142, 223, 400/U CABLE GROUPS.
 - FOR CABLE TRIMMING USE KTT-113 & KTD-166.
 - FOR FORMING USE CRIMP DIE SIZE 01.
 - FOR CABLING INSTRUCTIONS SEE CP-465
6. ITEM (2) TO BE SUPPLIED UNASSEMBLED.

UNLESS OTHERWISE SPECIFIED:

- TOLERANCES: FRACTIONS & 2 PLACE DECIMALS ± .010
3 PLACE DECIMALS ± .004
T. I. R. CONCENTRICITY OF ANY 2 DIAMETERS MAY NOT EXCEED HALF THE SUM OF THEIR TOLERANCES.
- REMOVE ALL BURRS, BREAK SHARP EDGES .005 MAX.
- NO FILLETS PERMITTED.
- SURFACE ROUGHNESS 63 MICROINCHES RMS MAX.
- ALL DIMENSIONS PRIOR TO PLATING.

ITEM	REQ'D	DESCRIPTION	PART NO.
6	1	CABLING INSTRUCTIONS	3-339-2M88
5	1	RETAINER RING	[REDACTED]
4	1	BNC CRIMP CAPTIVE CONTACT F	1-570-ZAM9D
3	1	INSULATOR	[REDACTED]
2	1	K-GRIP BODY	[REDACTED]
1	1	K-GRIP SLEEVE	1-4690-2MC7

M39012/17-0503

ISSUE	CHANGES
0.	ER 13618 LI 22 JUL 74
1	CN 13841A M.J.F. 11 OCT 74
2	CN 15974A GA 15 JUL 76
3	CN 23168 E MD 29 MAR 82
4.	CN 25533 D CT 14 DEC 83
5	CN 28193 A CHC 5 AUG 86
6	CN 28237 C CHC 18 AUG 86
7	CN 32278 A LNM 13 JUN 90

KC-39-106

USED ON:

REF:

FINISH:

SPEC:

MATL:

SPEC:

BNC JACK

DRAWN W.D. DATE 29 APR 74
APPR. LI DATE 22 JUL 74

KINGS ELECTRONICS
40 HARBLEDALE ROAD
TUCKAHOE, N. Y. 10707

M39012/17-0503

GSD